

**LICENCE FEE OF EXHIBITION VENUE**

Location	Area (L x W)	Licence Fee (HK\$ / day) (Effective from 01/02/2024)		Refundable Deposit (HK\$ / period)
		Weekday	Sat, Sun & Public Holiday	
Sheung Shui Centre* - L1	20' x 15'	\$4,800	\$8,500	\$5,000
	L2 Atrium 891 Sq.ft. (approx.)	\$6,500	\$10,500	\$5,000
Metro City Plaza 1** –	L2 (Atrium Lobby 1)	\$3,700	\$5,300	\$5,000
	L2 (Atrium Lobby 2)	\$3,700	\$5,300	\$5,000
	G/F (Location A)	\$2,200	\$3,100	\$5,000
	G/F (Location B)	\$1,900	\$2,500	\$5,000
West 9 Zone *** –	L2(Exhibition Venue 2F-A)	\$1,000	\$1,500	\$5,000
	L2(Exhibition Venue 2F-B)	\$1,000	\$1,500	\$5,000
	L2(Exhibition Venue 2F-C)	\$1,500	\$2,000	\$5,000

Remarks: 1) Minimum 3 days booking are required. For the venue of MCP1 G/F, 2 days booking are allowed.

- 2) **10% discount will be offered for any booking with 5 consecutive days or more (including Saturday & Sunday).**
- 3) **30% discount will be offered to the existing mall tenants for any booking (limited to 3 times per year) with 3 consecutive days or more (including Saturday & Sunday); the offer cannot be used in conjunction with other discount offer.)**
- 3) **15% discount will be offered for any booking of whole venue locations at the same shopping mall (i.e., SSC-L1 & L2 Atrium Or MCP1-L2 (Lobby 1 & 2) & G/F (Either Location A or Location B)) with 5 consecutive days or more (including Saturday & Sunday).**
- 4) **30% discount will be offered to new licensees (first time only) or the licensees launching thematic exhibition / roadshow related to Sports, Travel, Wine, Coffee & Tea and Green business (proposal / activity plan must be submitted for approval, the offer cannot be used in conjunction with other discount offer.)**
- 5) Insurance –

Licensor shall arrange sufficient third party liability insurance coverage with the limit not less than HK\$10,000,000 for the whole licence period. Copies of relevant documents need to be provided to the licensor not later than 5 days' prior to the Event.

\*For **Sheung Shui Centre**, the insurance policy shall be in the joint names of landlord (**Bayman Limited**) and the Property Manager (**Henderson Sunlight Property Management Limited**).

\*\*For **Metro City Plaza 1**, the insurance policy shall be in the joint names of landlord (**Sunlight Crownwill Limited**) and the Property Manager (**Henderson Sunlight Property Management Limited**).

- \*\*\*For **West 9 Zone**, the insurance policy shall be in the joint names of landlord (**Victory Wave Limited**) and the Property Manager (**Henderson Sunlight Property Management Limited**).
- 6) Two tables (Size: 2'x 6') without table skirting and one 13Amp socket will be provided upon request.
  - 7) Licence fee and deposit are subject to change without further notice.
  - 8) For booking enquiry, please kindly contact us at 3669 2721 or at 3669 2723 - Ms. Wan.

**LICENCE FEE OF EXHIBITION VENUE (Charity Rate)**

Location	Area (L x W)	Licence Fee (HK\$ / day) (Effective from 01/02/2024)		Refundable Deposit (HK\$ / period)
		Weekday	Sat, Sun & Public Holiday	
Sheung Shui Centre* - L1	20' x 15'	\$800	\$1,000	\$3,000
Metro City Plaza 1** – L2 (Atrium Lobby 1) G/F (Location A & B)	18' x 11'	\$800	\$1,000	\$3,000
	18' x 12'(approx.)	\$800	\$1,000	\$3,000
West 9 Zone*** – L2 (Location 2F-A) L2 (Location 2F-B)	5' x 10'	\$800	\$1,000	\$3,000
	5' x 10'	\$800	\$1,000	\$3,000

Remarks : 1) Minimum 3 days booking are required. For the venue of MCP1 G/F, 2 days booking are allowed.

2) Licence fee and deposit are subject to change without further notice.

3) The above rate is only offered to government, non-profit-making activities or charity organizations only.  
e.g. Y.M.C.A., Police Force, Tung Wah Group, Po Leung Kuk, Unicef, I.C.A.C. etc.

4) Insurance –

Licensee shall arrange sufficient third party liability insurance coverage with the limit not less than HK\$10,000,000 for the whole licence period. Copies of relevant documents need to be provided to the licensor not later than 5 days' prior to the Event.

\*For **Sheung Shui Centre**, the insurance policy shall be in the joint names of landlord (**Bayman Limited**) and the Property Manager (**Henderson Sunlight Property Management Limited**).

\*\*For **Metro City Plaza 1**, the insurance policy shall be in the joint names of landlord (**Sunlight Crownwill Limited**) and the Property Manager (**Henderson Sunlight Property Management Limited**).

\*\*\*For **West 9 Zone**, the insurance policy shall be in the joint names of landlord (**Victory Wave Limited**) and the Property Manager (**Henderson Sunlight Property Management Limited**).

5) Two tables (Size: 2'x6') without table skirting and one 13Amp socket will be provided upon request.

6) For booking enquiry, please kindly contact us at 3669 2721 or at 3669 2723 – Miss Wan.

08/24

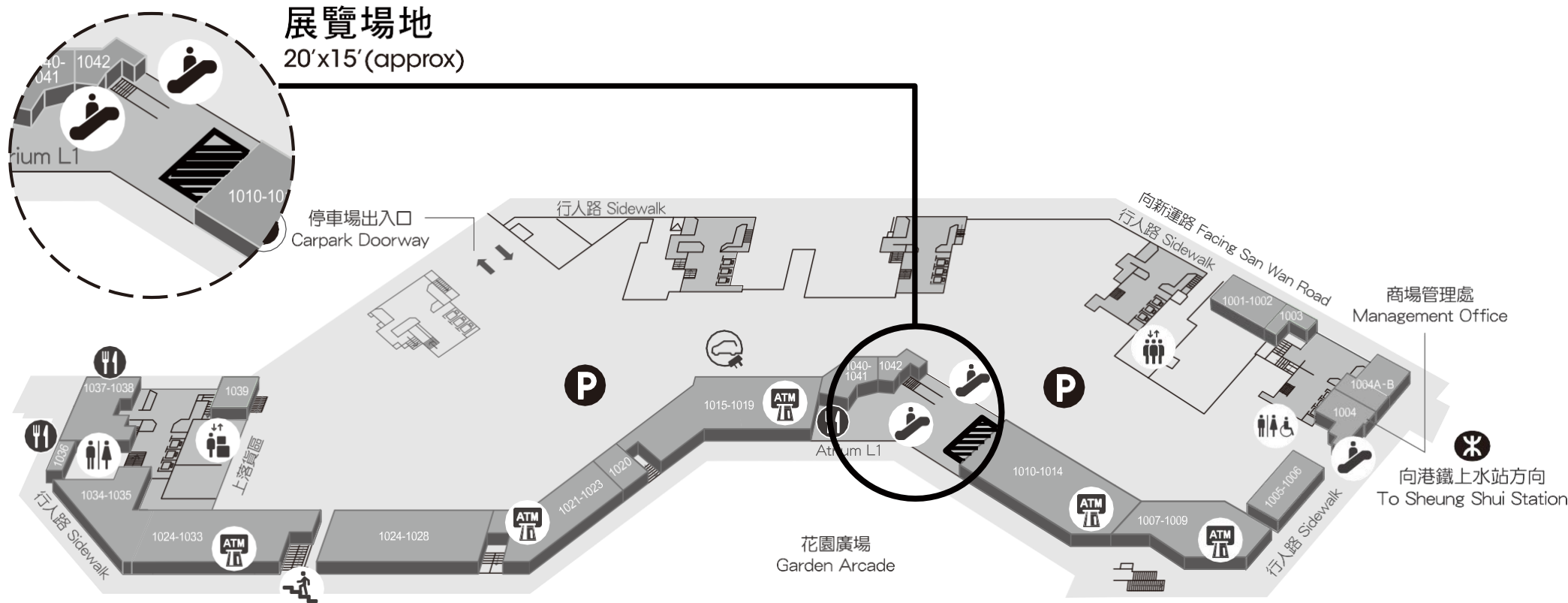

**展覽場地**  
20'x15' (approx)



上水智昌路3號(貼鄰港鐵上水站)  
3, Chi Cheong Road, Sheung Shui  
Floor plan are not in scale, for reference only. 圖則不按比例, 只供參考。



**SUNLIGHT REIT**  
陽光房地產基金

洽租查詢：  
**3669 2721 / 3669 2723**

**展覽場地**

39'x22' (approx) (約891sq.ft 平方尺)

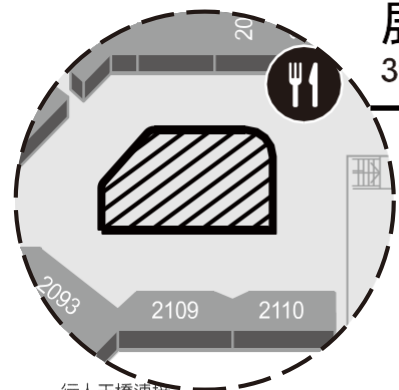

行人天橋連接  
上水名都  
Footbridge to  
Sheung Shui Town Centre

商場租務處  
Leasing Office

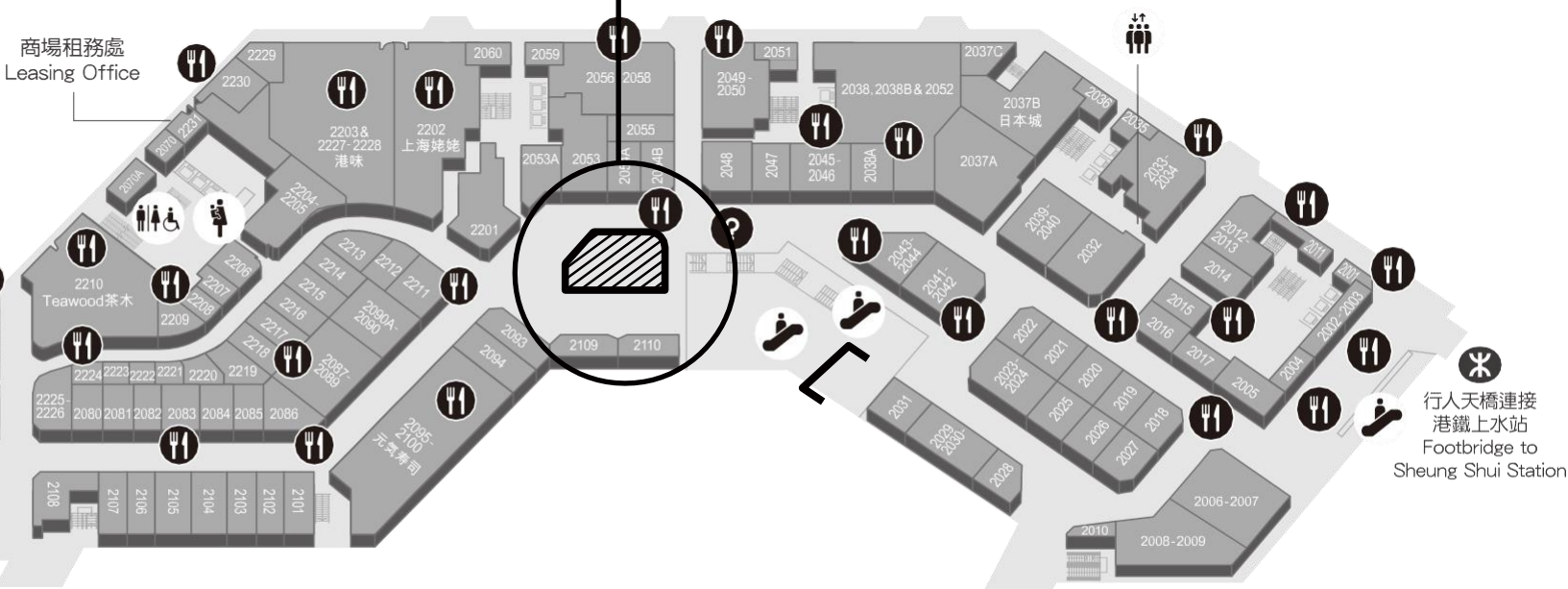

行人天橋連接  
港鐵上水站  
Footbridge to  
Sheung Shui Station

行人天橋連接新都廣場  
Footbridge to Metropolis Plaza

行人天橋連接石湖墟市政大廈  
Footbridge to Shek Wu Hui Municipal Building



上水智昌路3號(貼鄰港鐵上水站)  
3, Chi Cheong Road, Sheung Shui

Floor plan are not in scale, for reference only. 圖則不按比例, 只供參考。



**SUNLIGHT REIT**  
陽光房地產基金

洽租查詢：  
**3669 2721 / 3669 2723**

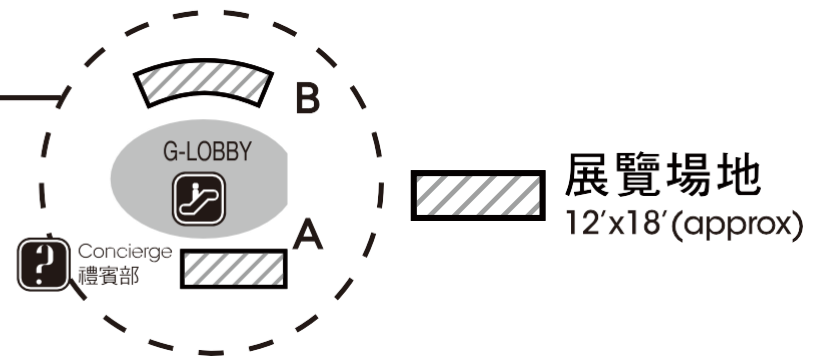
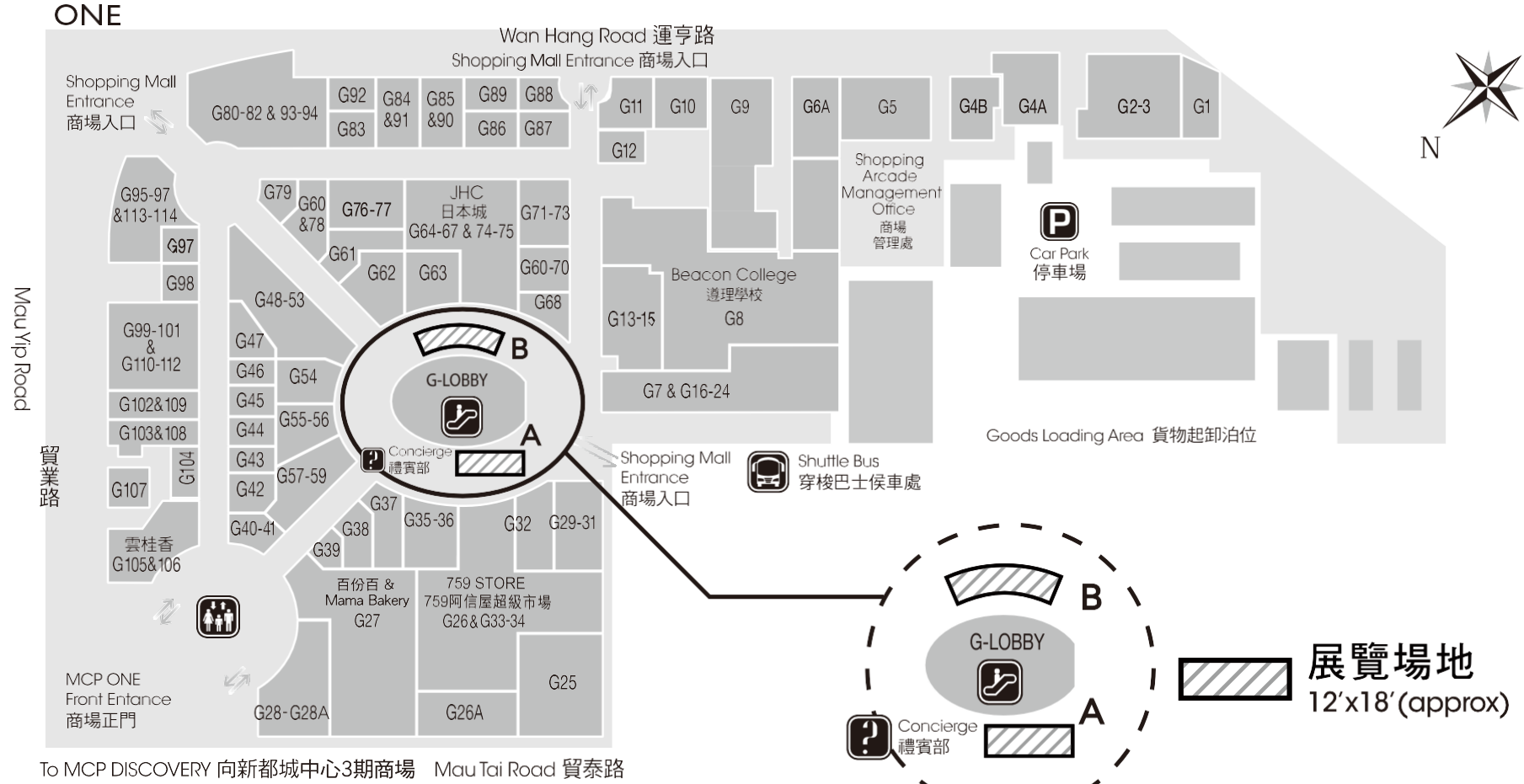

將軍澳運亨路 1 號  
1, Wan Hang Road, Tseung Kwan O



洽租查詢：  
3669 2721 / 3669 2723

Floor plan are not in scale, for reference only. 圖則不按比例，只供參考。

Footbridge to The Pinnacle 天橋 往 疊翠軒

Shopping Mall Entrance 商場入口

Footbridge to MTR and MCP CENTRAL  
行人天橋連接港鐵站及新都城中心二期商場

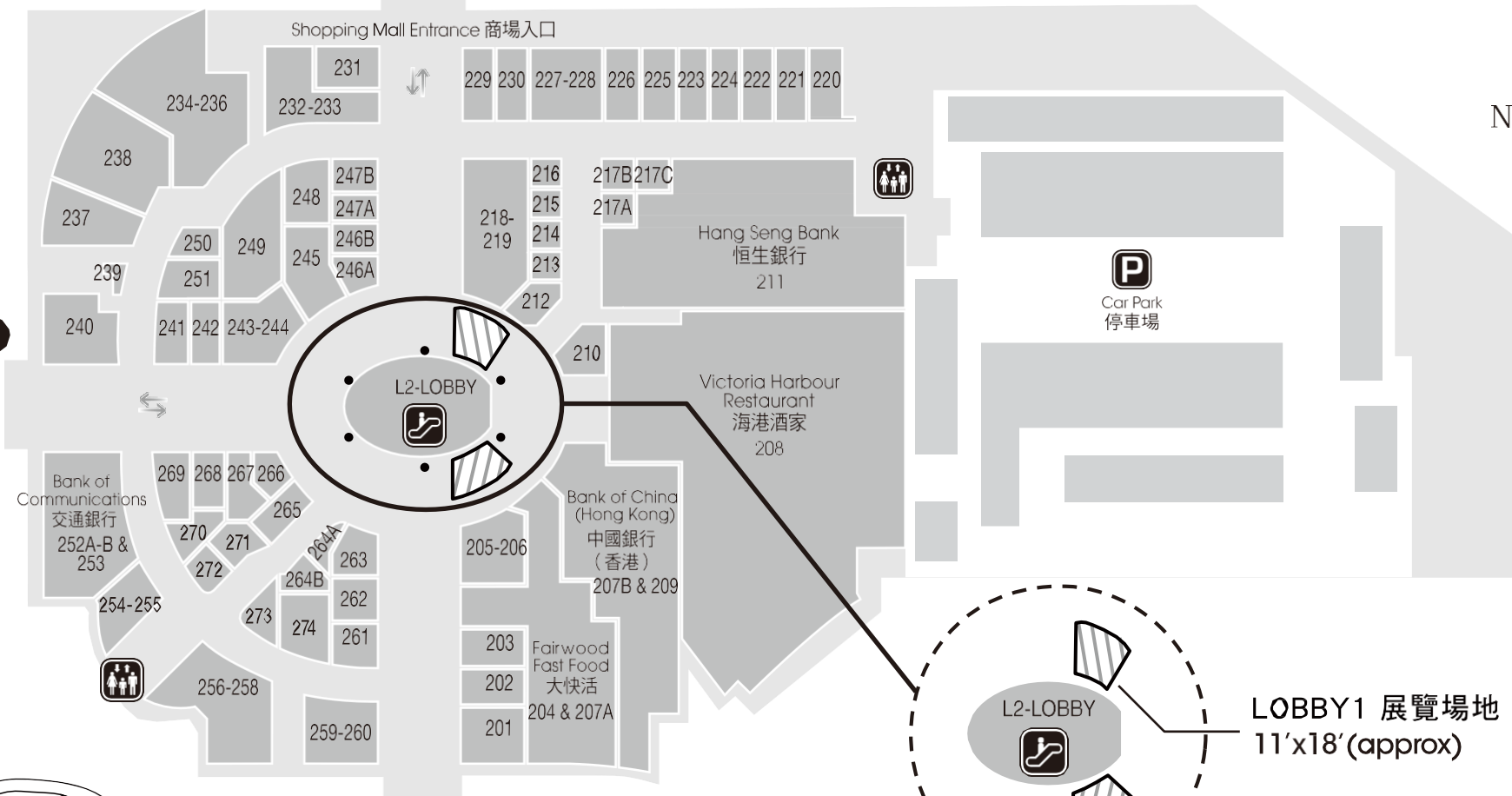

Footbridge to MCP DISCOVERY  
天橋 往 新都城中心3期商場

將軍澳運亨路 1 號  
1, Wan Hang Road, Tseung Kwan O

Floor plan are not in scale, for reference only. 圖則不按比例，只供參考。



SUNLIGHT REIT  
陽光房地產基金

洽租查詢：  
3669 2721 / 3669 2723

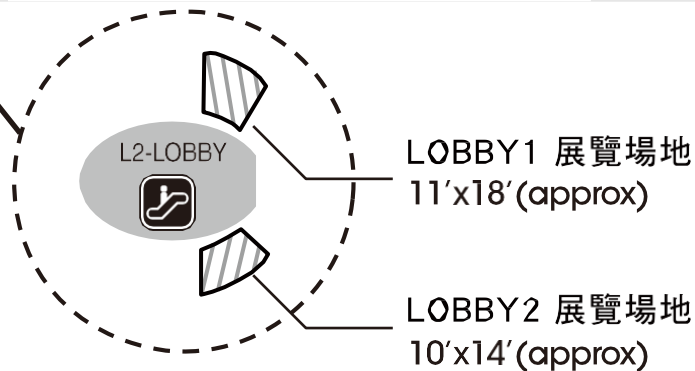

# WEST 9 ZONE

西九匯

## L2 Exhibition Area 二樓展覽場地

西九匯  
West 9 Zone

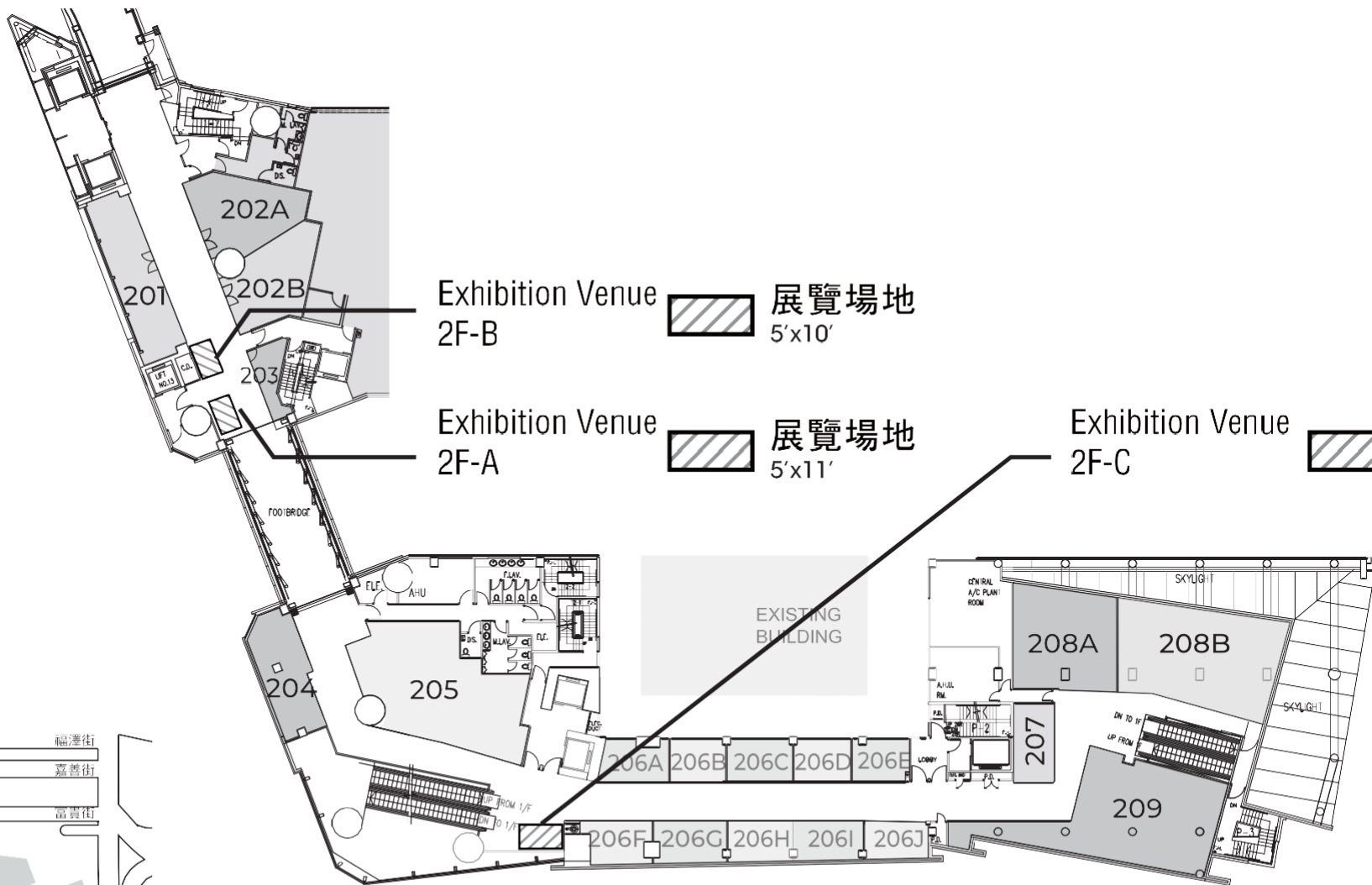

九龍大角咀櫻桃街38號  
38 Cherry Street, Tai Kok Tsui, Kowloon

Floor plan are not in scale, for reference only. 圖則不按比例, 只供參考。



SUNLIGHT REIT  
陽光房地產基金

洽租查詢：  
3669 2721 /

3669 2723